



WORLD'S PREMIER GAMES

888-538-1000
TEL (561) 588-5200
FAX (561) 493-2999
PARTS FAX (561) 493-2990
PARTS: (561)253-3311 SERVICE: (561)253-3310

51 Hypoluxo Rd.
Hypoluxo, FL 33462-4501
www.benchmarkgames.com

WHEEL DEAL X-TREME

USER/SERVICE MANUAL



**PLEASE READ FIRST BEFORE
PLUGGING IN MACHINE**

ALL RIGHT RESERVED. PAT. PENDING

105MAN-01-B



TABLE OF CONTENTS



- 1- BASIC COMPONENTS 2
- 2- GAME PLAY SEQUENCE/BEHAVIOR 4
- 3- GAME SETUP 6
- 4- TECHNICAL OPERATION 8
 - Inter-Board Communication 8
 - Main Electronic Components 9
- 5- PROGRAMMING OPTIONS 15
- 6- ERROR CODES AND TROUBLESHOOTING GUIDE 23
- 7- ELECTRICAL DIAGRAMS AND PIN-OUT TABLES..... pending
- 8- MECHANICAL SCHEMATICS pending
- 9- REVISION HISTORY Last Page

1- BASIC COMPONENTS

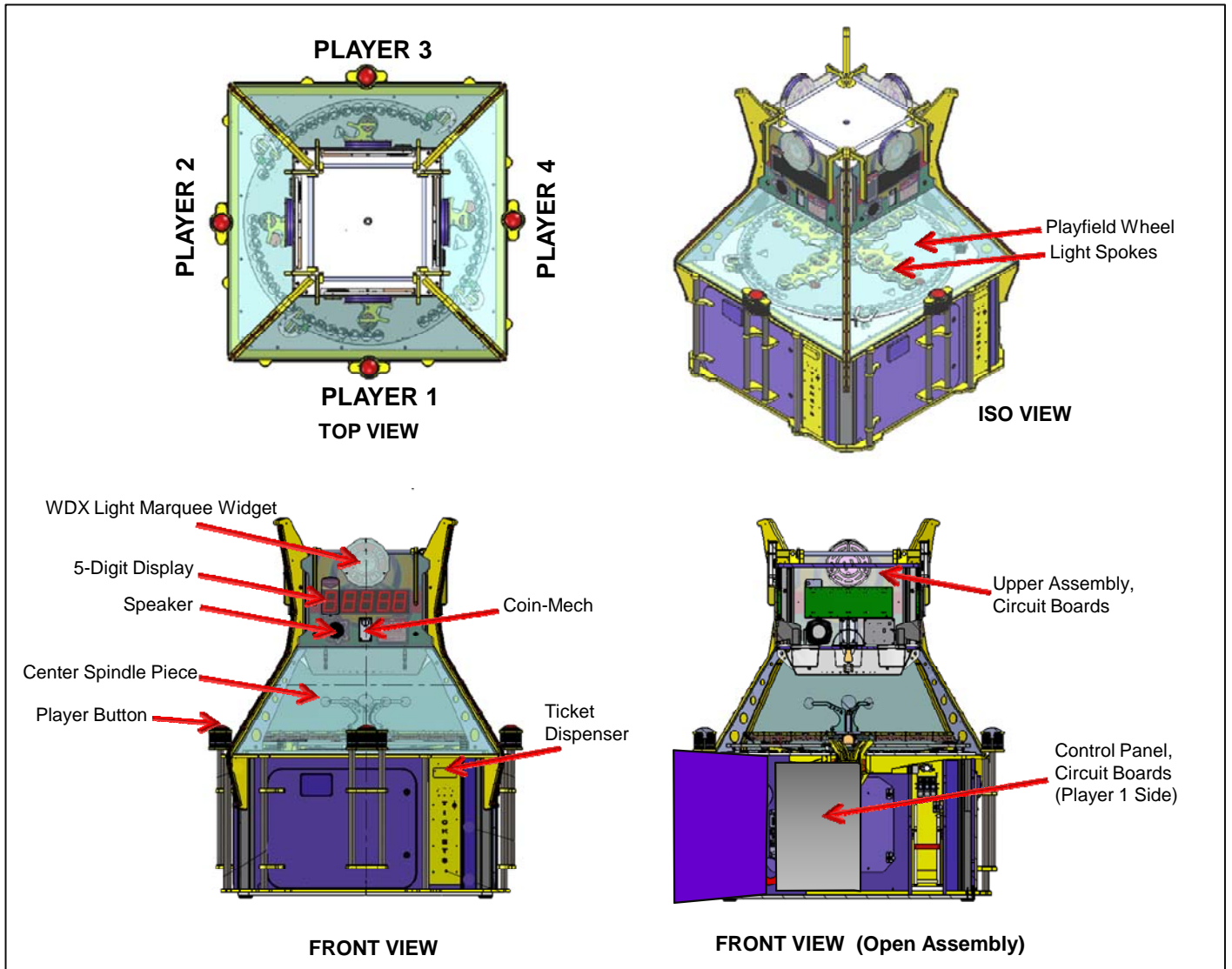

Figure 1. Overview of main components

The four player sides are numbered 1,2,3,4 in a clockwise fashion, beginning with the side where the control boards are located. Each player has a Button, Display, Speaker, Lights, Puck-Ramp, and Playfield sensor pair.

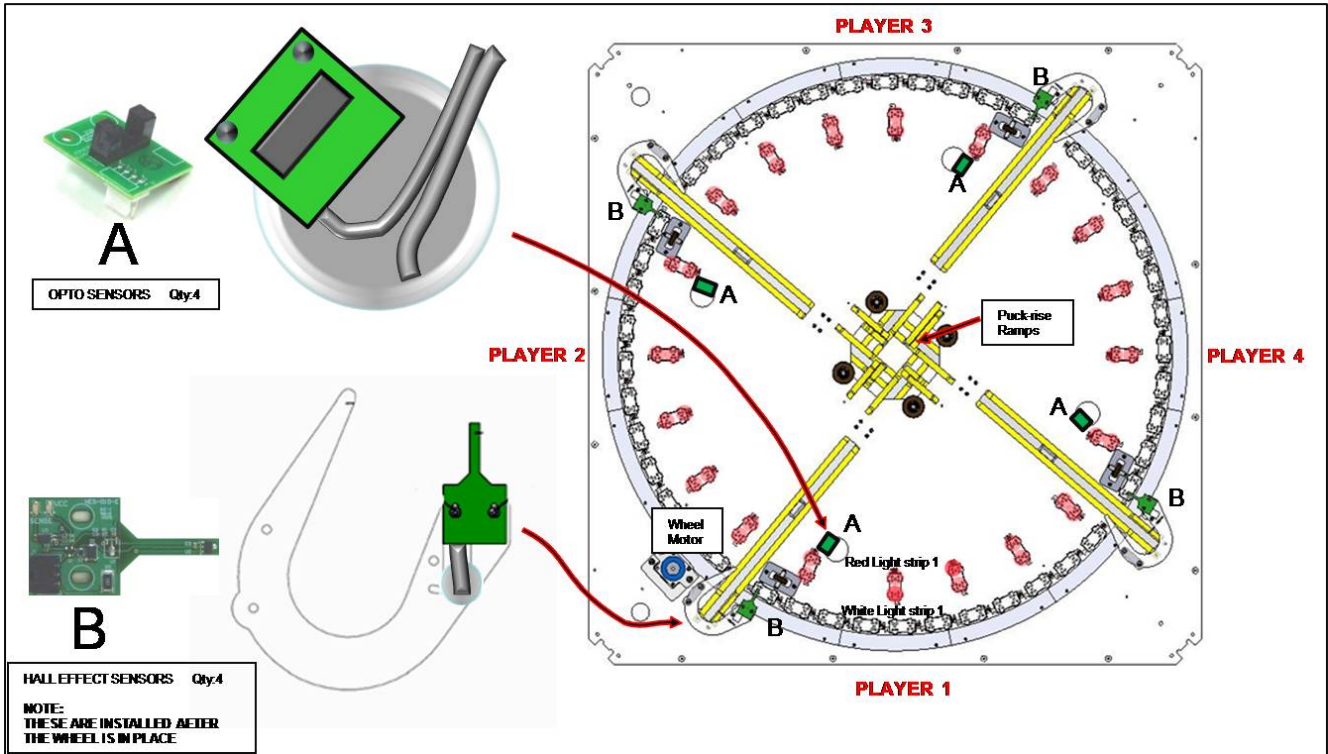

Figure 2, Game Sensors (Top View, wheel removed):
 Opto-Sensor: Detects Wheel Playfield-Start.
 Hall-Effect Magnet Sensor: Detects Puck at the end of its travel.

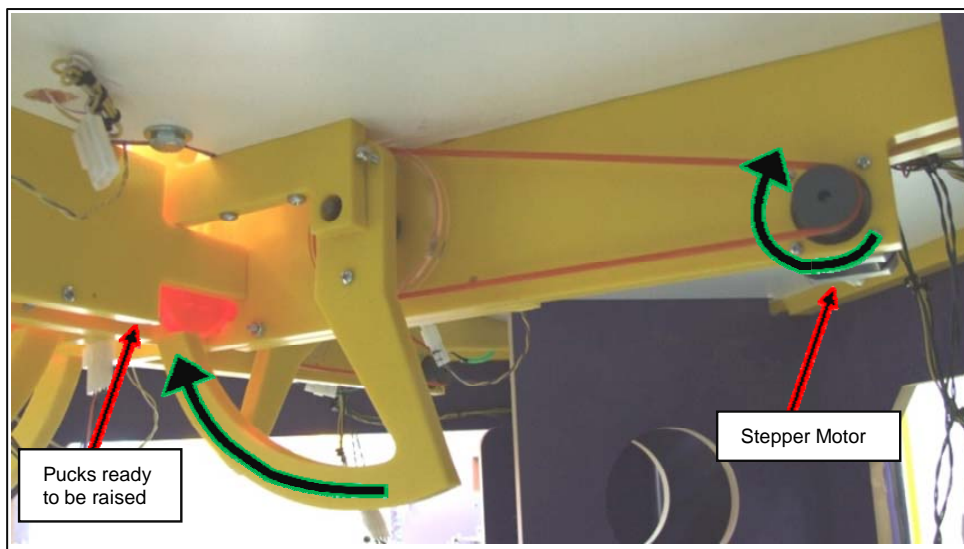

Figure 3, Puck Ramp Mechanism, Underneath Playfield Base.
 There's three actions taken by this ramp:
 Puck-load (seen in picture), Puck-Arm (ready to play), and Puck-Kick (play)

2- GAME PLAY SEQUENCE/BEHAVIOR

1-Power-up initialization Sequence (about 20 seconds):

This is useful to quickly confirm that the machine features are operational.

- Wheel will start rotating.
- Playfield White-Lights will light up, one player at a time (1,2,3,4, clockwise), also, Displays will show an attraction sequence.
- Pucks will then be kicked out one at a time (1,2,3,4 clockwise) and a sound will accompany each; this lets you know if the speakers/sound channels correspond to the appropriate player sides.
- When each Puck is detected by the corresponding Hall-Effect Sensor, you will hear a “chirp” sound, and the corresponding player lights will flash for a moment. This lets you know the Puck-detection system is in working order (for each player).
- Finally, the center-piece spindle will start spinning (counter-clockwise) pretty quickly for a few seconds, and then come back down to a slow speed.



II- Attraction Mode:

- Various light patterns are shown while the background sound plays on.
All these 'ease' down eventually to avoid being repetitive.

III- Player adds coins (Coin-Mech or Card-swipe system):

- "Coin-in" sound is heard on player-side.
- Common Jackpot value increments, shown on all four Displays.

IV- Credits are obtained:

- "Credits" digit on Display is incremented
(up to "9" shown; higher values are honored though).
- Play-mode start sound ("sweep" sound) is heard on corresponding player-side.
- Wheel Playfield Lights-up.

V- Player Hits Button:

- Puck is kicked into Wheel-Playfield by center Puck-ramp.
- Credit will be discounted.
- Play action sound is played on player side as puck makes its way down the wheel.
- Neon Lights flash momentarily.
- Puck travels down spoke-arm until it ends up over the wheel playfield targets.

VI- Puck is detected by Hall-Effect Sensor:

- Ticket Prize is awarded according to the following criteria:

>*Puck centered (aligned) over central Jackpot-Target:*

Jackpot-Fanfare is entered.

>*Puck centered (aligned) over any other target:*

"Dead Center Bonus" will be awarded (5 times the center prize value)

>*Puck not aligned:*

Prize will be awarded according to prize table found on player window.

The "Mystery Bonus" is a random value, up to 2.5 times the value of the center prize .

Note: See Programming Mode -> prize-table section on this manual to see how to set the ticket-values awarded.

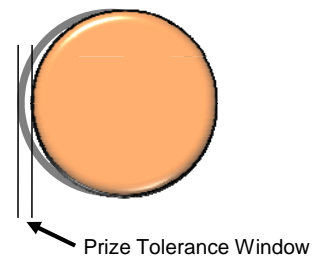

- Appropriate prize-sound will be called.
- Prize value awarded will flash on Display momentarily.
- Credit and Jackpot values will be updated on all four Displays if necessary.
- When done, game will come back to Play-mode or Attraction, depending on whether there are credits left or not.

3- GAME SETUP

Unloading/Assembly

The game is pre-assembled in the factory, all you have to do is unpack it and check/locate the following:

- The Game-door keys are tie-wrapped to Player1 Button.
- There's a "Crystal Ball" stored inside Player 1's Ticket-drawer. This should go inside the playfield area, laying over the center piece spindle. No fastener or glue is required.
- There should be 5 Play-Pucks per player, already loaded on their corresponding ramps, under the playfield board.
Inspect this by peeking under one of the lower doors.
- Remove any shipping foam that might still be holding any parts, specially the playfield pointers (spokes).
- Check wheel moves freely, listen for any friction. You should mainly feel the drag of the motor.
- The power cord is also stored inside Player 1's Ticket-drawer. Connect this to the power supply, inside Player 1's lower door. Route the cord, passing it through the hole on the left bottom corner of the cabinet (Player 1's side).

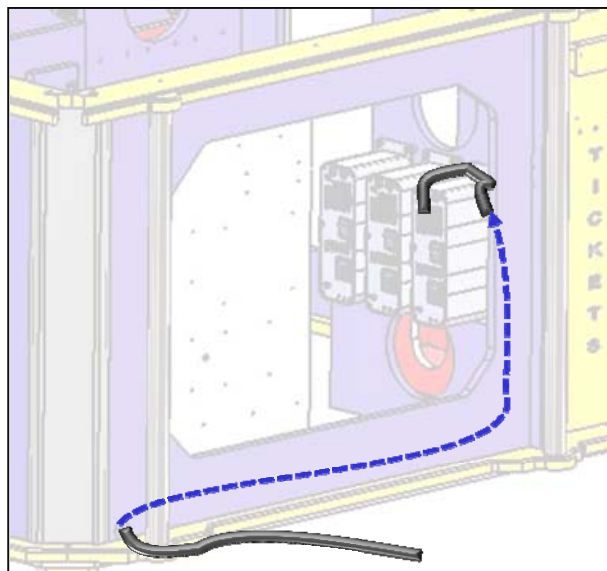

Power up

Plug-in the machine and turn it ON from the Switch located on the Power supplies.

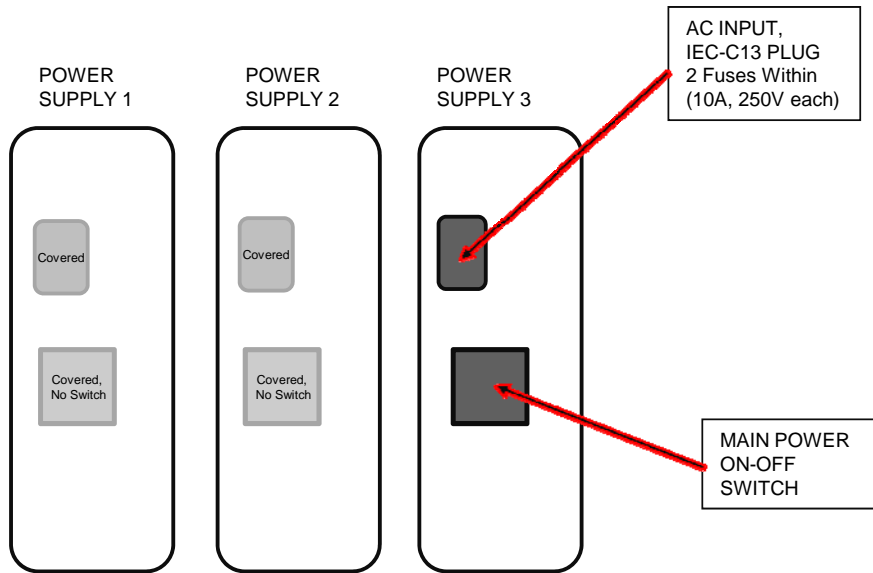

-Observe the Initialization sequence, as described in section 2-1.
Any major anomaly, if present, should be seen at this point.

Note: There are two AC fuses on the Power supply group (10Amp, 250V each). It is found inside of the ICE-C13 receptacle on the power supply. The other power supplies are in series with this one.

First-Time Setup

- Run through the 'Programming Mode' options and define your desired settings, like sound volume etc (See Section 5).
- Run the 'Calibration Routine' on 'Programming Mode' to ensure game accuracy is in order (See section 5-13). Note that this calibration is done in the factory, but it's best to re do it in the field, in case vibration during shipping or other factors moved things around.
- During and after calibration, try the game with the acrylic windows removed, so you can manually place the Play-Puck in the Jackpot position, etc.

4- TECHNICAL OPERATION

Inter-Board Communication

The Circuit Boards communicate with each other using a 485 differential wire-pair network, using the SNAP software protocol layer.

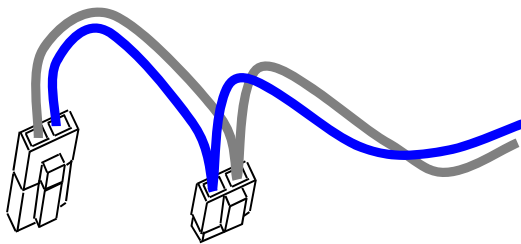

- On this machine, this wire pair has colors Blue and Gray.
- The Main CPU Board acts as the master, initiating commands and receiving responses.
- Like-boards differentiate from each other by means of an ID-Switch setting. See the following pages to find each board's ID-Switch location and setting.
- Note that the following boards are NOT connected to the 485 network:
 - > The Power distribution boards.
 - > The LCD Display.
 - > The Opto and Magnet Sensors. Each of these has a direct line to the appropriate target board's logic Inputs .
- Note that the 485 network wire-pair chain jumps from board to board:
 - > In some places the chaining is done by double-crimps at the connector (these are usually 2-pin connectors)
 - > In other places, PCB traces on the board itself carry the chain from a pair of connector pins to the next (usually a four-pin connector); thus, disconnecting such a board's 485 might actually disconnect the rest of the 485 chain. Keep this in mind when troubleshooting or replacing parts.

Main Electronic Components

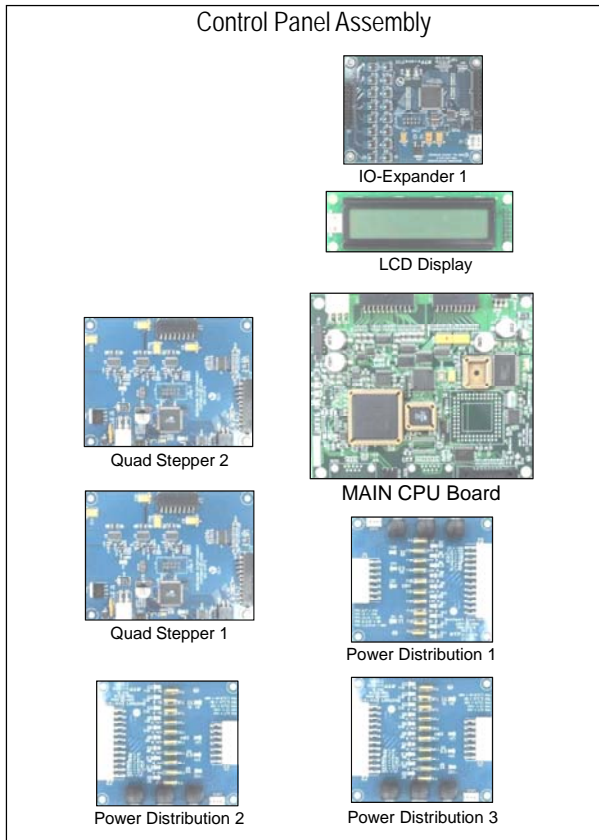

Figure 5. PCB Boards, Control Panel

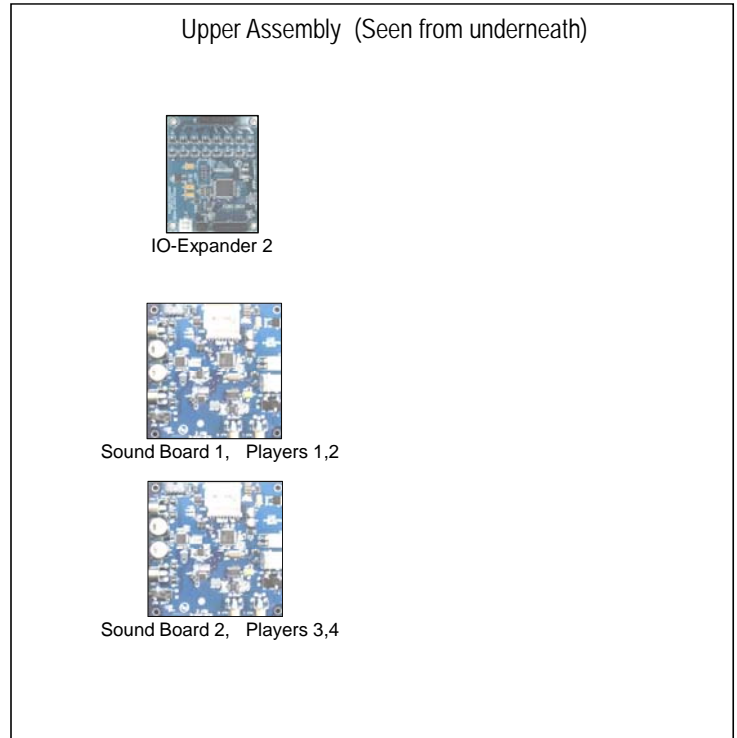

Figure 6. PCB Boards, Upper Assembly

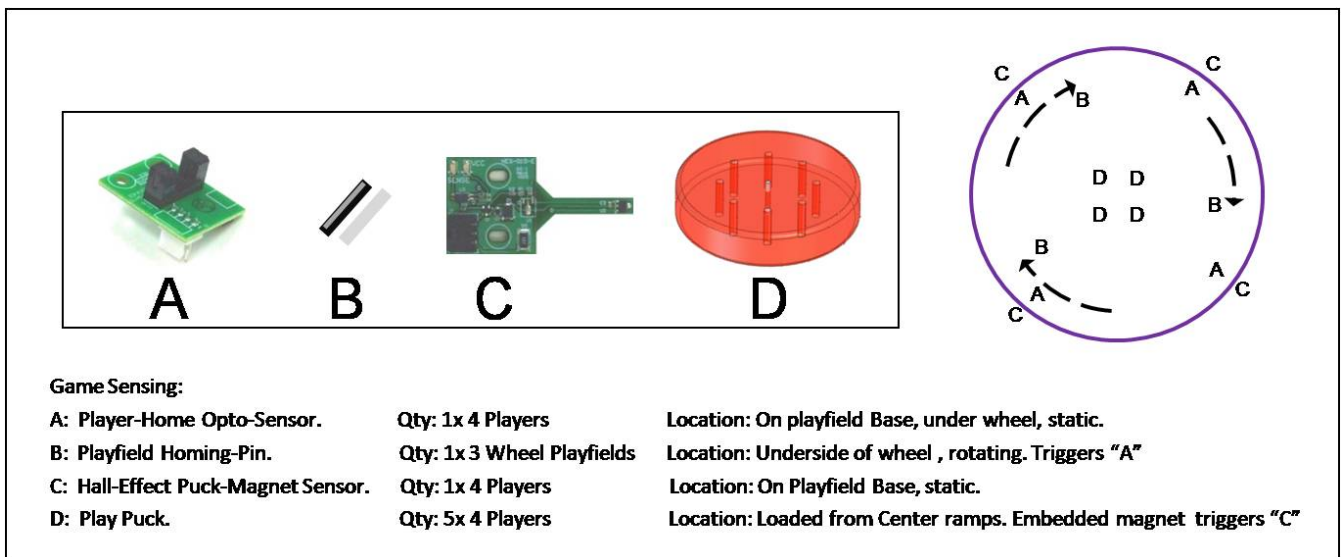

Figure 7. Sensing Components

Power Distribution Boards

Part# PCB17001

Location: Control Panel.

ID-Switch setting: None, board has no computer.

Distributes DC power from the power-supply to the different devices, through a Poly-Switch (thermal, resettable fuse) for each voltage circuit. The game uses a power distribution board for each power supply.

Power distributed in the following manner:

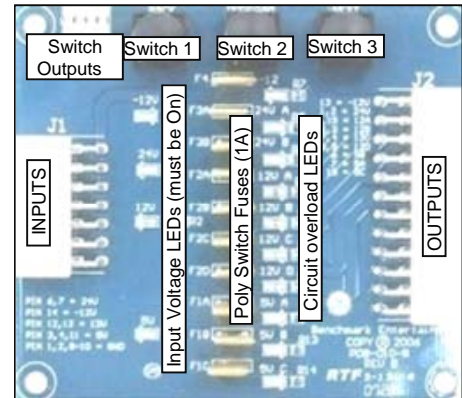

POWER DISTRIBUTION BOARD 1 (UNDER LCD DISPLAY):

- IO-Expander 1 (on main assembly)
- Wheel Spoke Lights
- Wheel Light Strips
- Button Lights
- Neon Lights
- TOTAL: $(12V \times 7.9A) + (24V \times 1.2) = 114W$

Fuse Circuit (estimated values)

- (12V, 100mA) (*12A*)
- (12V, 3A) (*12A*) (*12B*) use only *A* for now
- (12V, 4A) (*12C*) (*12D*) use only *C* for now
- (12V, 920mA) (*12D*)
- (24V, 1.2A)

POWER DISTRIBUTION BOARD 2 (BOTTOM LEFT):

- IO-Expander 2 (on top marquee assembly)
- Coin-Mechs
- Widget lights (WD-X)
- Sound Boards
- Displays
- TOTAL: $(12V \times 5.7A) + (24V \times 1.6) = 108W$

- (12V, 100mA) (*12A*)
- (12V, 800mA) (*12A*)
- (12V, 1.6A) (*12B*)
- (12V, 3.2A) (*12C*)(*12D*)
- (24V, 1.6A)

POWER DISTRIBUTION BOARD 3 (BOTTOM RIGHT):

- Main CPU
- Opto Sensors
- Hall Effect Sensors
- Ticket Dispensers
- QUAD STEPPER 1 (upper)(4 Puck Ramp Motors)
- QUAD STEPPER 2 (lower)(2 Wheel Motors)
- TOTAL: $(5V \times 150mA) + (12V \times 7.22) = 87W$

- (5V, 150mA) (*5A*)
- (5V, 60mA) (*5A*)
- (12V, 60mA) (*12A*)
- (12V, 800mA) (*12A*)
- (12V, 3.6A) (*12B*)(*12C*) use only *B* for now
- (12V, 1.8A) (*12D*)

Related Note:

Note: There is only one AC fuse on the Power supply group (7Amp, 250 V). It is found inside of the ICE-C13 receptacle on the main power supply (the other power supplies are in series with this one).

Main CPU Board

Part# PCB10002

Location: Control Panel

ID-Switch setting: None, this is the master board.

This board is the main controller of the game. It decides all the game actions and commands the other boards to act according to the game scheme.

Communication to the other boards is performed via a 485 differential wire-pair (Gray and blue wires).

The 'Programming Mode' game-settings information is also saved on this board.

The actual Game code resides on the removable Flash-Rom chip (U4); this chip can be replaced/upgraded if necessary (Using a PLCC32 extractor tool).

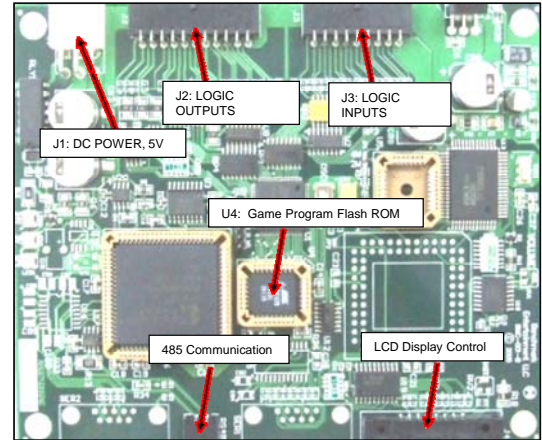

Quad Stepper 1

Part# PCB11006

Location: Control Panel (see figure)

ID-Switch setting: **00** (off-off)

This Stepper-motor controller board handles the movements of the four puck-loading ramp motors.

Quad Stepper 2 (part# PCB-000)

Part# PCB11006

Location: Control Panel (see figure)

ID-Switch setting: **10** (on-off)

This Stepper-motor controller board handles the Playfield Wheel rotation motor, and the center-spindle motor.

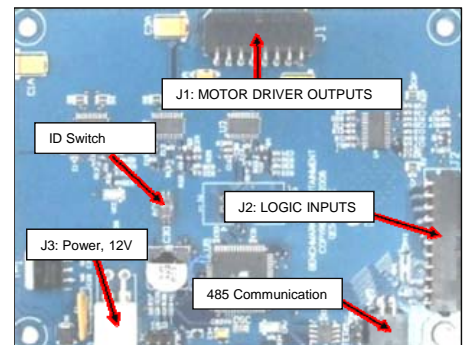

IO-Expander 1

Part# PCB14008

Location: Control Panel

ID-Switch setting: **0000** (off-off-off-off)

Handles the current as well as the patterns shown on the playfield LED-strips, the LED's under the wheel-arms, and the LED 'Neon' strips in the corners of the game.

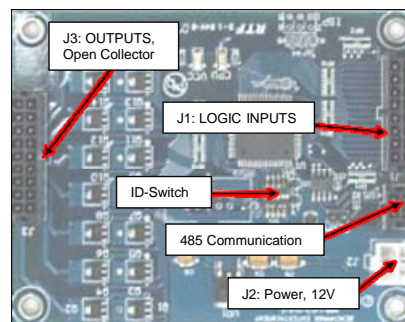

IO-Expander 2

Part# PCB14008

Location: Upper Assembly (see figure--)

ID-Switch setting: **1000** (on-off-off-off)

Handles the current as well as the patterns shown on the "Wheel Deal X" marquee lights on the upper assembly.

Sound Board 1 (part# PCB-000)

Part# PCB18001

Location: Upper Assembly, towards player 1 side

ID-Switch setting: **0000** (off-off-off-off)

Handles background and event sounds for players 1 and 2.
Sound files are stored on a plug-in SD-card Memory board.
Note that SD-cards on both sound boards hold identical sound-file sets.



Sound Board 2

Part# PCB18001

Location: Upper Assembly

ID-Switch setting: **0100** (off-On-off-off)

Important Note: Do not use 1000 as the ID setting, this tells the sound board to enter its own internal program upload mode upon power-up, causing the 485 network lines to be tied-up and making the game non-responsive. This is a non-destructive situation though, just set the ID switch back to the proper value and reboot.

Handles background and event sounds for players 3 and 4.
Sound files are stored on a plug-in SD-card Memory board.
Note that SD-cards on both sound boards hold identical sound-file sets.

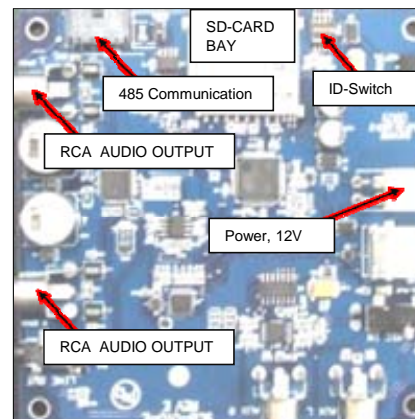

Player-Home Opto Sensors

Part# PCB---

Location: On Playfield Base, under Wheel.

Qty: x4 (1 for each player side)

ID-Switch setting: None, it has no 485 communication.



Detects the beginning of each Wheel playfield as it goes past the player side (the underside of the wheel has a pin for each playfield which interrupts the Opto's IR beam). The signal is passed along as a low-level voltage transition (through a single wire, no 485) to the Quad-Stepper-2 Board, where the step position is annotated.

Note: This board has a Green LED that lights up when the IR beam is interrupted.

Puck-Magnet Hall- Effect Sensors

Part# PCB---

Location: On Playfield Base, peeking over wheel playfield.

Qty: x4 (1 for each player side)

ID-Switch setting: None, it has no 485 communication.

Detects the magnet embedded on the center of the Play-Puck, after It travels through the playfield.

The signal is passed along as a low-level voltage transition (through a single wire, no 485) to the Quad-Stepper-2 Board, where the step position is annotated and compared to the one previously obtained from the Opto-sensor. This value difference determines the position hit on the play field.

The Main CPU board also receives this signal, so it can immediately request the position-hit report from the Quad Stepper Board.

Note: This board has a Red LED that lights up when a magnet is detected.

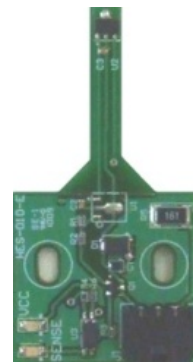

Large 5-Digit Displays

Part# PCB13007

Location: On Upper Assembly.

Qty: x4 (1 for each player side)

ID-Switch settings:

Player 1: **000000** Player2: **100000** Player3: **010000** Player4: **110000**

The ID-Switch is located on the back of the Display and is labeled as "S1".

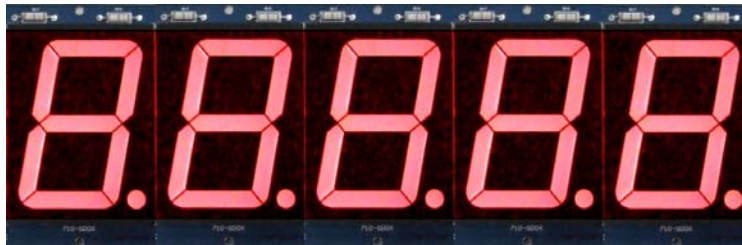

Ticket Dispensers (Intelli-Triple Series)

Part# PCB13007

Location: Ticket Side-Doors

Qty: x4 (1 for each player side)

IMPORTANT NOTE: These ticket dispensers for Wheel-Deal-X DO NOT use the standard "Run" and "Notch" lines to communicate with the main CPU Board; instead, they do it through the 485 comm. network.

Because of this, you must be sure these devices have code version TDT 1.7 or higher (see sticker on PC-Board).

They also need to have the proper ID switch settings, as follows.

ID-Switch settings:

Player 1: **000000** Player2: **100000** Player3: **010000** Player4: **110000**

The Circuit-board and ID-Switch within are part of the Ticket Dispenser device, on the underside.

For more information, see Benchmark's Ticket Dispenser manual.

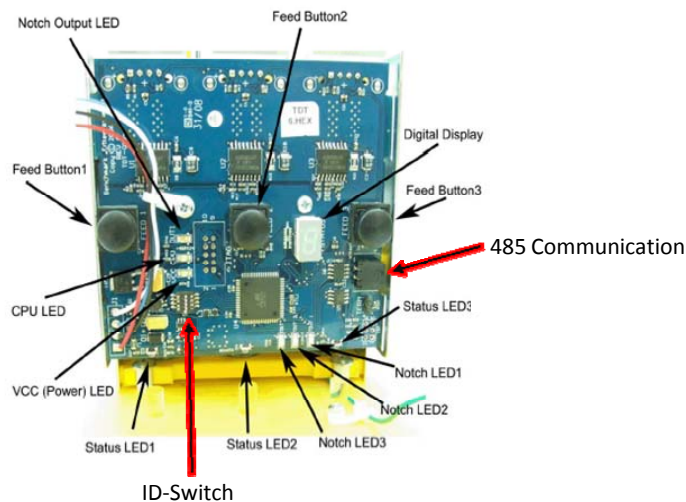

5- PROGRAMMING OPTIONS

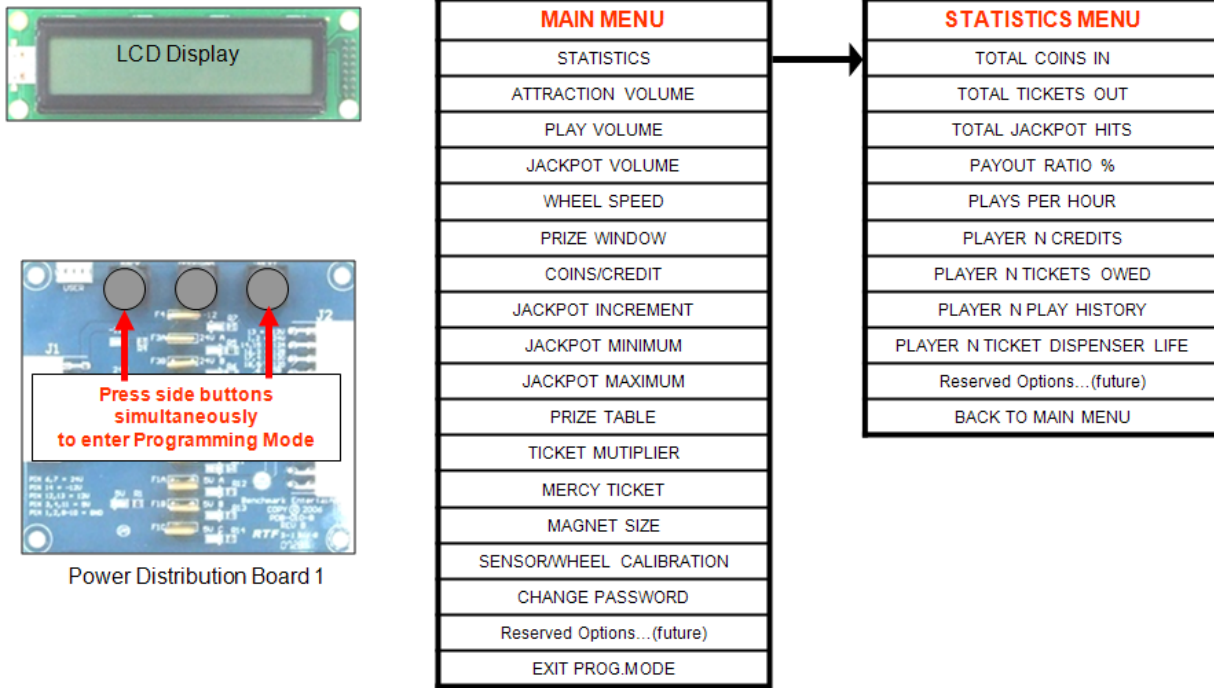
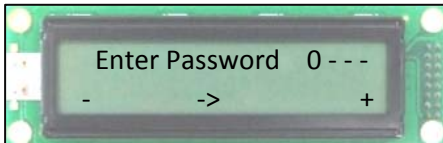

Figure 8. Programming Mode Menus.
 Button Assignments: Left: "Decrement", Center: "Enter", Right: "Increment"

To enter Programming mode:

I- Press the side buttons on Power Distribution Board 1, as shown in figure 8.

II- Enter Password



Main Button assignments:

Left button: Decrement. Center Button: Enter Right Button: Increment

III- Follow the menus as shown in figure 8. Descriptions of the options follow this page.

MAIN MENU

1- STATISTICS

Takes you to the Sub-Menu that shows game totals and results (see page 20)

2- ATTRACTION VOLUME

Background music volume When Player not present.

Value Range: 0-100% Default: 25%

3- PLAY VOLUME

Background music and event volume, when Player has credits.

Value Range: 0-100% Default: 25%

4- JACKPOT VOLUME

Background music volume, when a Player wins the Jackpot, heard on all four sides.

Value Range: 0-100% Default: 25%

5- WHEEL SPEED

Speed of the Playfield Wheel

Value Range: 0-20 (slow-fast) Default: 10

6- PRIZE WINDOW

How close should the Play-Puck align with the prize-targets for it to be considered a hit.

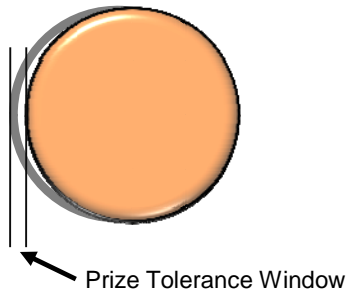

This adjustment goes in units of about 0.002" (0.05mm), but on the menu, we take steps of 5 units: about 0.01" (0.25mm).

Value Range: 5-40 Default: 20

(Note: values below 20 are not recommended, as winning becomes overly difficult)

7- COINS PER CREDIT

How many Coin-Mech device pulses are required to add +1 credit (1 game chance).

Value Range: 1 – 4 Default: 1

8- JACKPOT INCREMENT

Amount by which the Common Jackpot increases with each coin added.

Value Range: 1 – 10 Default: 5

9- JACKPOT MINIMUM

Initial-value for the Common-Jackpot. (Note: each unit represents one ticket)

This value is set after the last Jackpot is awarded.

Value Range: 200 – 1000 Default: 300

10- JACKPOT MAXIMUM

Limit-value for the Common-Jackpot. (Note: each unit represents one ticket)

Credits after this value is reached won't increment it further.

Value Range: 1000 – 9999 Default: 9999

11- PRIZE TABLE

There are several playfield payout tables that can be chosen, depending on your location.

These Ticket-Prize tables break down as follows:

PAYOUT TABLE										10 JACKPOT	mystery bonus							Dead Center Bonus (x5 center prize)	Mystery Bonus (~x2.5 center prize)
A	1	2	3	4	5	6	7	8	10 JACKPOT	mystery bonus	7	6	5	4	3	2	1	50	1 to 26
B	2	3	4	5	6	7	8	10	16 JACKPOT	mystery bonus	8	7	6	5	4	3	2	80	2 to 40
C	3	4	5	6	7	8	10	12	20 JACKPOT	mystery bonus	10	8	7	6	5	4	3	100	3 to 50
D	4	5	6	7	8	10	12	16	30 JACKPOT	mystery bonus	12	10	8	7	6	5	4	150	4 to 80
E	5	6	7	8	10	12	16	20	40 JACKPOT	mystery bonus	16	12	10	8	7	6	5	200	5 to 100
F	6	7	8	10	12	16	20	26	50 JACKPOT	mystery bonus	20	16	12	10	8	7	6	250	6 to 120
G	7	8	10	12	16	20	26	30	60 JACKPOT	mystery bonus	26	20	16	12	10	8	7	300	7 to 150
H	8	10	12	16	20	26	30	36	70 JACKPOT	mystery bonus	30	26	20	16	12	10	8	350	8 to 180
I	10	12	16	20	26	30	36	40	80 JACKPOT	mystery bonus	36	30	26	20	16	12	10	400	10 to 200

You can choose among tables A–I. Note that the artwork on the player window will have to correspond to those values.

Keep in mind that the “Dead Center” Bonus and the “Mystery” Bonus will be proportional to the table chosen, as seen on figure.

Keep in mind that you still have to setup your “Game Price” and the “Jackpot” Settings independently of this, depending on the ‘winnings’ you want.

For example, you can set table “E”, with a price per play of four coins (\$1), and a Jackpot between 300 and 9999 tickets, with a jackpot increment of 5 (This was our main testing setup).

Alternatively, you could set a cheaper price, say \$0.50 per play, set table “C”, and set a jackpot increment of 3. This would give about the same (ticket/\$) ratio, but people might actually play a lot more (or less).

You can play with these combinations to see which settings get the most out of the machine in your area.

Value Range: A-I

Default: E

12- MERCY TICKET

Some jurisdictions require a ticket award under all circumstances.

This allows you to set the number of tickets awarded, when player does not win any prize on wheel.

Value Range: 0 – 4

Default: 0

13- MAGNET SIZE

The 1.2 game version onwards (from 10-01-09) is shipped with play-pucks that have 1/8" diameter magnets, to achieve even greater play reliability. This will make the game easier to setup.

The corresponding Game-ROM versions 1.2 and higher allow you to adjust for this diameter;

However, the default setting already works for 1/8", so you normally won't have to change this setting.

Value Range: 1 – 10 (x1/32")

Default: 4 (1/8")

14- HALL-EFFECT MAGNET SENSOR, HEIGHT AND CENTERING-CALIBRATION

SENSOR HEIGHT

The sensor element needs to be between 1 and 3 mm (about 1/16") above the embedded magnet in the center of the Play-Puck. This height can be tweaked by adjusting the screw on the side of the sensor assembly, the one with a spring underneath (see figure).

-First loosen the 5/16" (8mm) set-nut that holds everything still, using a 1/4" (6.5mm) wrench to hold the main stand in place.

-Turn the Phillips adjustment screw to obtain the proper gap between puck and sensor.

-Carefully retighten the set nut to hold everything back together.
Do not over-tighten.

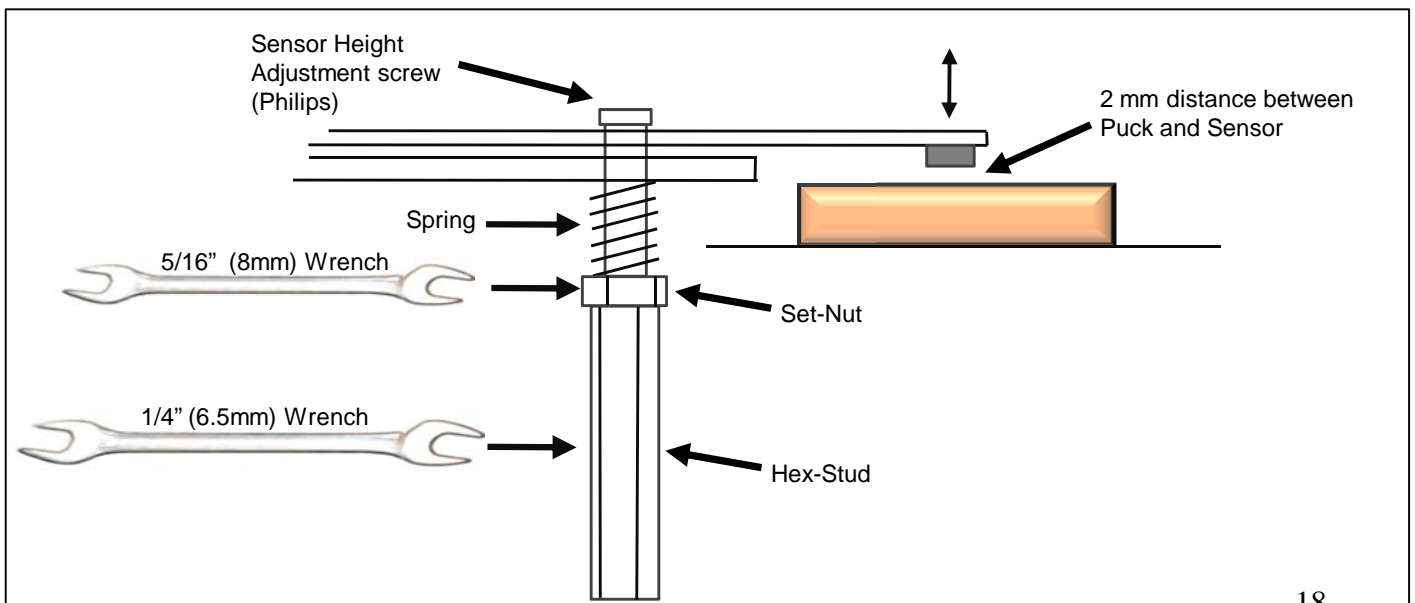

Figure 9. Sensor Height Adjustment

SENSOR CENTERING

Sensor positioning calibration is necessary to compensate for hardware variations; This calibration is done independently for each of the four player sides.

Note:

This is performed once on the factory floor after final assembly, but because of possible vibration during shipping, it is recommended to do it again during first-time field-setup.

When you enter this mode, you will be prompted to calibrate Player 1. You can hit 'Enter' to skip to players 2, 3 and 4, or you can hit the side buttons to change the setting value.

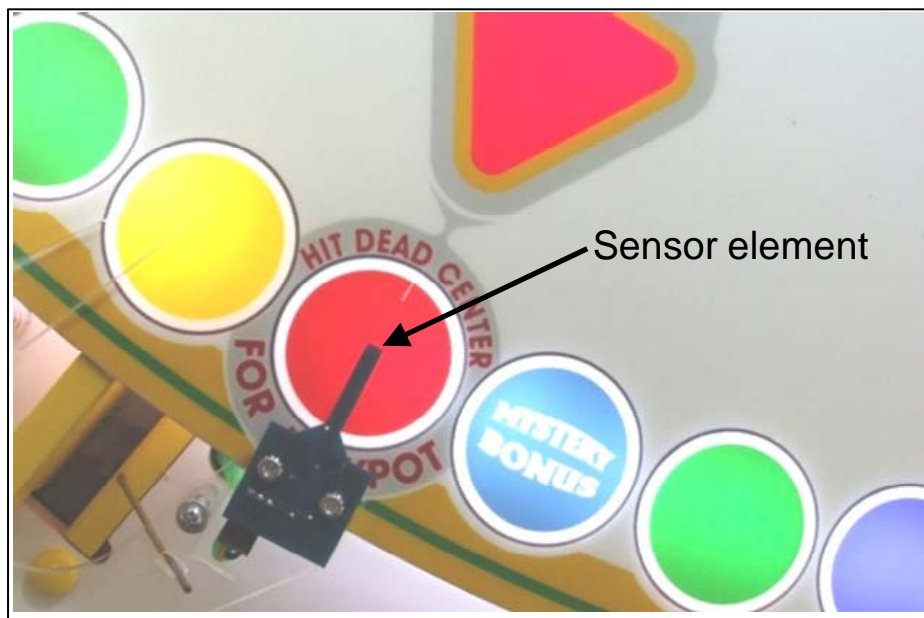

Figure 10. Calibration Routine.

The wheel will automatically run and position the Jackpot Prize under the Puck-Sensor of the corresponding player (see figure 10).

Place one of the orange Play-Pucks centered over the Jackpot-Target on the wheel, being careful not to disturb the wheel position (see figure 11).

The goal is to adjust the sensor-element's relative position, so that it is centered over the magnet embedded in the center of the puck (see figure 11); This is accomplished by moving the physical location of the sensor (loosening the Phillips screws holding the PCB-board to the Acrylic assembly), and/or by adjusting the offset value shown on the LCD display.

Ideally, one would leave an offset value of "0" on the LCD option, while adjusting the physical position of the sensor (this is the way it is done the first time in the factory).

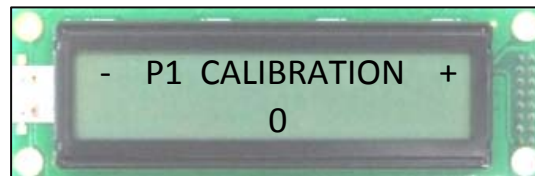

If there is still a small deviation, you can finely adjust the offset value on the LCD. Decrementing this value will turn the wheel counter-clockwise, while Incrementing it will turn it Clockwise. You have a range of about ¼" in both directions.

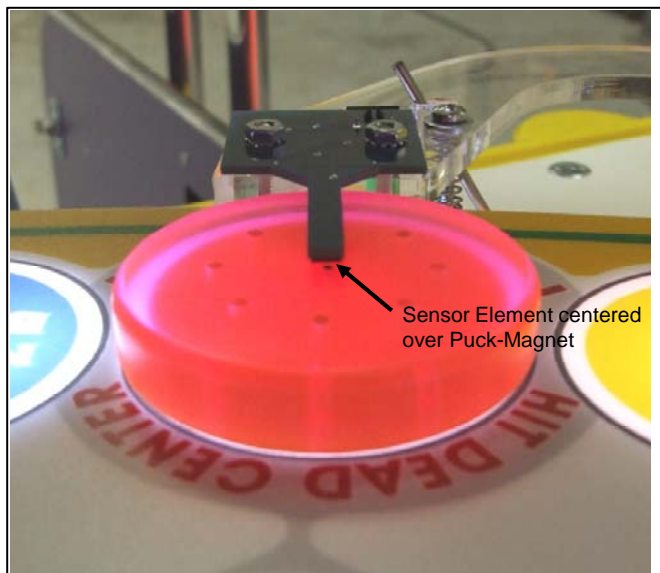

Figure 11. Calibration Routine Detail.

Once the sensor is straight over the puck-center, hit 'Enter' to set the value.

Again, be careful not to move the wheel by accident as this is done; if in doubt, you can always re-enter calibration-mode to double check your setting.

Repeat these steps for Players 2, 3, and 4 if necessary.

15- CHANGE PASSWORD

The default game password number is 0000; It is recommended that you change this number to keep your settings secure.

Enter four numbers just as you did when first calling Programming Mode; you will then be asked to confirm this, hit 'Yes' to set it.

Note: If you lose your password number, you will have to contact Benchmark's Technical Support to receive a back-door entry number.

16- EXIT PROG MODE

Returns machine to operational mode

STATISTICS MENU

TOTAL COINS IN

Total including all four players.

Hit 'Enter' to take this back to zero (you will be prompted for confirmation).

TOTAL TICKETS OUT

Total including all four players.

Hit 'Enter' to take this back to zero (you will be prompted for confirmation).

TOTAL JACKPOT HITS

Total including all four players.

Hit 'Enter' to take this back to zero (you will be prompted for confirmation).

PAYOUT RATIO

Total including all four players.

This is basically $(\text{TotalTickets})/(\text{TotalCoins}/\text{CoinsPerPlay})$, assuming a standard \$0.01 ticket value and a coin value of \$0.25

Example: 2800 Tickets/ 100 Plays = 28%

This calculation may vary depending on your location's actual ticket and coin values; always double check with your own numbers.

Hit 'Enter' to take this back to zero (you will be prompted for confirmation).

PLAYS PER HOUR

Total including all four players.
Hours include actual running time (power ON).

This is a better indicator than the Pay-Out-Ratio alone for the actual return of the machine, since a lower or higher Payout-Ratio does not necessarily translate into higher income.
Just multiply this number by your actual play-price (and then multiply by your pay-out ratio) to know the effective hourly return.

Hit 'Enter' to take this back to zero (you will be prompted for confirmation).

PLAYER N, TICKETS OWED

This shows the value for Players 1, 2, 3, 4, separately.
How many tickets are still due by the corresponding Ticket Dispenser device.
Hit 'Enter' to take this back to zero; Ticket Dispenser will stop.

PLAYER N, PLAY HISTORY

This shows the value for Players 1,2,3,4, separately.
You can see the last five game results for the corresponding player (the left-most is the oldest one).
These are the result codes:

- X = No-Hit/Error
- Number = Ticket-award determined by payout table.
- DC = Dead Center Bonus (Puck line-up with non-Jackpot prize)
- JK! = Jackpot (Puck line-up with Jackpot Prize)

Hit 'Enter' to clear these (you will be prompted for confirmation).

PLAYER N, TICKET DISPENSER LIFE

This shows the value for players 1, 2, 3 ,4, one at a time.
How many tickets have been given by the corresponding Ticket Dispenser device since its last mechanical service.
It is recommended to service these devices after about one million tickets. See the TD manual or contact Benchmark's Tech-Support for more information.
Hit 'Enter' to take this back to zero (you will be prompted for confirmation).

BACK TO MAIN MENU

Exits Statistics Menu.

6- ERROR CODES AND TROUBLESHOOTING GUIDE

ERROR CODES, QUICK SUMMARY

Shown on the corresponding player 5-Digit Display overhead.

Note: Errors are more clearly spelled out on the LCD display on the Control Panel.

- E1: Quad Stepper Board 1, Communication Error.
- E2: Quad Stepper Board 2, Communication Error.
- E3: Out-of-Tickets condition (on the corresponding player side).
- E4: Ticket Dispenser, Communication Error (on the corresponding player side).
- E5: Sensor Error, (Opto-sensor or Magnet-sensor, on the corresponding player side).
- E6: IO-Expander Board 1, Communication Error.
- E7: IO-Expander Board 2, Communication Error.
- E8: Sound Board 1, Communication Error.
- E9: Sound Board 2, Communication Error.

TROUBLESHOOTING GUIDE (next page)

TROUBLESHOOTING GUIDE

#	SYMPTOM	POSSIBLE CAUSES / ACTIONS	SEE RELATED SYMPTOMS:
0	It doesn't work	Multiple. Plug the game to a wall receptacle and determine more exactly what features don't work.	All
1	E1, E2, E4, E6, E7, E8, E9 Error codes (Inter-Board Communication Errors)	See Error code summary or LCD-screen to determine which circuit board has trouble > Check board has power, Vcc-LED should be lit. > Check board program is running, heartbeat LED should be flashing > Check on-board ID-switch setting. > Check 485 communication connector for proper crimping and polarity (try flipping 485 connector or its pins) > Check that all boards are connected to the 485 network, remember that in some of them, a disconnect will break the rest of the 485 chain. > Check 485 communication connector on Main CPU Board	9 10
2	E3 Error code: Out-of-Tickets	Ticket dispenser on corresponding player side is jammed or ran out of paper. > Clear jam or reload more tickets into drawer. Press button underneath Ticket dispenser device to reset it.	1
3	E5 Error code: Possible Sensor Error	Opto-Sensor or Hall-Effect Magnet-Sensor on corresponding player side are possibly not functioning. Note: there is no 485 communication line pair between sensors and the other boards, they're not part of that 'network' (no need to check for such here). > Make sure all Wheel-playfield home-pins (underneath) reach down enough (5/8") to trigger the Opto. > Check Opto sensor by rotating wheel until a Wheel-playfield home-pin (underneath) crosses the IR beam, the on-board light (Green LED) should light up. > Check Opto sensor power and signal connector. This is an IDC-type connector, one must ensure wires are not pulled-out or loose. > Measure Opto Sensor power (red and black wire pair) for 5V. > Check Hall-Effect Sensor by placing a Play-Puck under sensing element, the on-board light (Red LED) should light up. > Check Hall Effect Sensor power and signal connector, watch for any loose crimp. Measure power (yellow and black wire pair) for 12V.	
4	Wheel won't turn	> Check for Quad stepper2 Board power (Vcc LED On) > Check Quad stepper Board 2 program is running, (green LED flashes slowly) > Check Quad stepper Board 2 communication-485, including on-board ID-switch setting. > Check Wheel Motor is connected > Check motor movement while pulling it away from wheel contact, reboot if necessary, so it does the startup wind-up sequence. Motor force is not too strong, but it should have a smooth, continuous movement. > If motor won't run but it stills tries to move (hums or vibrates): > Check motor connector for proper pin-out > Check wiring harness for proper pin-out (see electrical tables), by measuring continuity between points; do this with the motor disconnected. > Check that wheel moves freely, without any binding. For this test, swing the motor away from the wheel edge, so they don't have any contact: > Wheel should be fairly loose, a strong swing should give you about half a turn. > If there is excessive drag, inspect around to find a possible binding point. > Check the center bearing-wheels (white plastic) for drag in any of them. > Check the under-side bearing-wheels (under wheel, brown plastic) for drag; you may have to prop the wheel up or remove it to gain access.	9 10 1 5
5	Center Spindle won't turn	> Check for Quad stepper Board 2 power (LED On) > Check Quad stepper Board 2 program is running, (green LED flashes slowly) > Check Quad stepper Board 1 communication-485, including on-board ID-switch setting. > Check Motor is connected > If motor won't run but it stills tries to move (hums or vibrates): > Check motor connector for proper pin-out > Check wiring harness for proper pin-out (see electrical tables), by measuring continuity between points; do this with the motor disconnected. > Check for free mechanical movement. Do this with the power off.	9 10 1
6	Puck-Ramp(s) won't move	> Check for Quad stepper Board 1 power (LED On) > Check Quad stepper Board 1 program is running, (green LED flashes slowly) > Check Quad stepper Board 1 communication-485, including on-board ID-switch setting. > Check Motor is connected > If motor won't run but it stills tries to move (hums or vibrates): > Check motor connector for proper pin-out > Check wiring harness for proper pin-out (see electrical tables), by measuring continuity between points; do this with the motor disconnected. > Check for free mechanical movement of the ramp. Do this with the power off.	9 10 1
7	Playfield Red lights don't light up	> Check for proper connections. See Electrical schematics/tables. > Measure 12V at the connection point (this may require removal/prop-up of the wheel to gain access) Note that these Red lights are not CPU controlled, they are tied up directly to DC power (always ON) > If connections are fine, test with a spare light-strip (if available). Failure of the actual LED light-devices is extremely rare, but still a possibility,	21 22 23
8	Playfield White lights don't light up	> Check for IO-Expander Board 1 power (LED On) > Check IO-Expander Board 1 program is running, (green LED flashes slowly) > Check IO-Expander Board 1 communication-485, including on-board ID-switch setting. > Check for proper wiring connections between board and lights, by measuring continuity. See Electrical schematics/tables > If connections are fine, test with a spare light-strip (if available). Failure of the actual LED light-devices is extremely rare, but still a possibility,	9 10 1

9	PCB Board not powered (Vcc LEDs off)	<ul style="list-style-type: none"> > Check power connector is properly inserted and the pin crimps are not loose > Check power voltage on input pins. (see board description for voltage value) > Check Power Distribution Board(s) > Check power wiring continuity, see Electrical schematics/tables. > Exchange position with a like-board to rule-out the board itself. (I.e. swap the two Quad Stepper boards), if the same board is still Off, it is most likely damaged; otherwise it is a power/wiring problem. 	21 22
10	PCB Board powered (Vcc LED On), but no heartbeat LED flashing	<ul style="list-style-type: none"> > Try rebooting the machine to see if program restarts properly. > Replace / reprogram board 	
11	Sounds are not heard	<ul style="list-style-type: none"> > Check corresponding Speaker is properly connected > Check RCA speaker connection to Sound Board on top assembly. > Check order of RCA connectors to Sound Boards, they might have been swapped and the sounds are just being heard on other player's side. NOTE: POWER MUST BE OFF TO MOVE THESE AROUND; OTHERWISE THE AUDIO AMPLIFIERS MIGHT GET DAMAGED. > Check Sound Boards for power and communications. > Check on-board ID-switch setting > Swap SD sound-Memory-Card from the other Sound Board to rule-out that current SD memory is faulty or empty. 	9 10 1
12	Sound is distorted/pops	<ul style="list-style-type: none"> > Check the Sound Board power connector (white Mini-Fit type), it must have ground (black wires) on both pins 1 and 2 (the bottom pins); by means of a jumper or wire-loop. > Add it if not present or one is missing. > Swap SD sound-Memory-Card from the other Sound Board to rule-out that current SD memory is faulty or corrupted. > If the above two did not work, the audio-amplifier on the Board might be faulty and you may need to change the Board. Swap the two Sound Boards to confirm this. 	910
13	Sounds are heard on the wrong speaker	<ul style="list-style-type: none"> > Check order of RCA connectors to Sound Boards, they might have been swapped. NOTE: POWER MUST BE OFF TO MOVE THESE AROUND; OTHERWISE THE AUDIO AMPLIFIERS MIGHT GET DAMAGED. 	1 11
14	"WDX" marquee lights don't light up	<ul style="list-style-type: none"> > Check for IO-Expander Board 2 power (Vcc LED On) > Check IO-Expander Board 2 program is running, (green LED flashes slowly) > Check IO-Expander Board 2 communication-485, including on-board ID-switch setting. > Check for proper connections between board and door-assembly / lights. See Electrical schematics/tables > If connections are fine, test with a spare light-strip (if available). Failure of the actual LED light-devices is extremely rare, but still a possibility, 	9 10 1
15	5-Digit Display is dead, no lights at all.	<ul style="list-style-type: none"> > Check that power is getting to the board; measure 24V over the orange and black wire pair (pins 4(left-most) and 3 of the Micro-Fit connector, respectively). > If power is present, the board might be bad, since you should be able to see all "8's" on power-up, even with a communication failure. > Check Upper-Door interface connector > Check Power Distribution Boards > Check power wiring continuity all the way to Display. DO THIS WITH THE POWER OFF. 	9 21 22
16	5-Digit Display is On, but won't update, or wrong value	<ul style="list-style-type: none"> > Check IO-Expander Board 2 communication-485, including on-board ID-switch setting. > Check 485 communication connector for proper crimping and polarity (may try flipping comm. pins). > Check 485 communication wiring continuity all the way to on Main CPU board. See Electrical schematics/tables 	1 17
17	Incorrect number of credits are displayed	<ul style="list-style-type: none"> > Credits are displayed using the leftmost-digit of the Display only, thus more than '9' credits will still appear as '9', until you reach a lower value. > Check Display communication-485, including on-board ID-switch setting. > Check Coin-Mech by adding credits (insert coins or toggle bypass switch on its back), if OK, you should hear the corresponding game-credit sound. > Check Coin-Mech device connector, measure power (5V) over red and black connector pair > Check Coin-Mech signal wire for proper connection. > Check Coin-Mech wiring continuity to power and Main CPU board signal-input. See Electrical schematics/tables 	1
18	Incorrect prize awarded	<ul style="list-style-type: none"> > Run Calibration routine on Programming Mode. See 'Programming-Options' on user manual > Check Opto-sensor > Check Wheel-playfield home-pins (underneath), these are the ones that trigger the Opto-Sensors, make sure they're present and that they reach down enough (5/8") to trigger the Optos. > Check Hall-Effect Puck-sensor > Make sure Prize Table corresponds with the proper Main CPU Firmware. > Check 'Player Play-History' on Programming-mode\Statistics. Write down the values for the corresponding player. This will be useful if you contact Tech-Support. 	3
19	No prize awarded	<ul style="list-style-type: none"> > Check Playfield White-Lights when playing and puck goes under Hall- effect sensor (given that you have credits), if lights flash, then puck-detection is fine. <ul style="list-style-type: none"> > Check and see if you hear the prize sound-event being called? if not, check Sound Board and speaker, do you still here the other events? > Check Ticket Dispenser. > If lights won't flash when puck goes under sensor: <ul style="list-style-type: none"> > Check Sensor height setting; there should be a distance of about 1/16" between sensor element and play puck. Adjust as necessary. > Check Hall-effect sensor > Check wiring continuity between sensor and power and to Main CPU Board input. See Electrical schematics/tables 	2
20	Play-Button won't work	<ul style="list-style-type: none"> > Check to see if Button-Light flashes momentarily and sound-event is called when you press button (given that you have credits), If light flashes and sound is heard, button-detection is fine: <ul style="list-style-type: none"> > Check Puck Ramp (mechanics, motor) > Check Quad-stepper Board 1 > Check Communication wiring continuity between Main CPU Board and Quad-stepper Board 1 > If Button-light won't flash when pressed: <ul style="list-style-type: none"> > Check wiring continuity between Main CPU inputs/outputs and Door-hinge interface connector. See Electrical schematics/tables > Check Button-switch and Button-light for power and continuity to Door-hinge interface. You may have to take apart the Button Assembly. 	11 13 6
21	Power Distribution Board(s) Voltage LED's not lit up	<ul style="list-style-type: none"> > Check connection from corresponding power supply. > Check corresponding power supply for AC interconnect to the other power supplies. > Measure Input/output Voltages to/from the Power Distribution Board, it could be just the LED's that are bad (that would be rare though). > Swap Power Boards around to check for any difference; if so, you might want to replace the Power Board in question. 	23

22	Power Distribution Board(s) Fuse-Short LED(s) lit up	<ul style="list-style-type: none"> > Check which voltage-circuit-LED is indicating a short/overload (5V,12V,24V), See the Power-Distribution section of the User Manual to determine which device(s) are being powered by the fuse circuit indicated. > Turn off the machine, disconnect the power to the devices/boards related to the fuse, power-up again and see if LED short indication goes away. <ul style="list-style-type: none"> >If LED turned Off: <ul style="list-style-type: none"> > Start reconnecting power to the boards, one by one, to determine the culprit. (NOTE turn the machine Off for each try. Hot-plugging the boards is NOT recommended) > Once you determine which board is creating the overload, swap it for a like-board (if possible), determine if the problem is internal to the board in question, in which case it needs to be replaced. > If LED still On: <ul style="list-style-type: none"> > Measure continuity between the positive and negative lines of the given voltage-circuit, to determine if there is a blatant short in the wiring. Do this with the boards still disconnected, including the Power Distribution Board. 	9
23	Power supply(s) not working	<ul style="list-style-type: none"> > Check AC fuse (7Amp,250V) on Power-Supply, replace if necessary. If problem persists, try to observe machine to determine where the short/overload is. On AC side, the center light-bulb might be related. On DC side, Observe power Distribution Boards. Note: There is only one AC fuse on the Power supply group. It is found inside of the ICE-C13 receptacle on the power supply. The other power supplies are in series with this one. > If only one Power-supply seems defective: Confirm this by swapping power from one of the other power supplies, to the corresponding Power Distribution Boards. You might have to replace the power supply. Contact Tech-Support 	
24	Center light-bulb won't light up	<ul style="list-style-type: none"> > Turn-Off the machine. Do Not touch any AC contact. > Check Light-bulb. Swap with a known-good bulb to see if voltage line is working. Replace bulb if necessary. > Check AC-Extension connections both at the base, by the power supplies, and on the Top Assembly. Note: This extension climbs through the right-hand side leg to the Top Assembly. 	

7- ELECTRICAL SCHEMATICS

Pending.

Go to Benchmark's website ('downloads') for the current pin-out tables and provisional diagrams.

8- MECHANICAL SCHEMATICS

Pending

9- REVISION HISTORY

-09-14-09: REV-A Created

-09-22-09: Added information regarding ticket prize-tables and how to choose them on Programming Mode

-09-28-09 Added Cover Page, updated pictures to reflect no-number targets.

-10-05-09 REV-B Created

Updated 'Programming-Options' figure and descriptions for "Prize Table" and "Magnet size" options, and "Current Credits" log. Added explanation on why/how ticket dispensers use 485 network. Game-ROM version is 1.2 at this point.

